



OIL PUMP TYPE AL GEAR SIZES 35-55-65-75-95

AL

AL - 11 - Ed 11 - Aug. 2002

This is a general specification leaflet; for specific applications not covered herein, contact Suntec.

The SUNTEC AL oil pump incorporates a blocking solenoid valve with in-line cut-off function.

APPLICATIONS

- Light oil.
- One or two-pipe system.

PUMP OPERATING PRINCIPLE

The gear set draws oil from the tank through the built-in filter and transfers it to the nozzle line via the cut-off solenoid valve. A pressure regulating valve is used to dump all oil which is not required at the nozzle.

In two-pipe operation, the by-pass plug must be fitted in the return port, which ensures that the oil dumped by the regulating valve is returned to the tank and the suction line flow is equal to the gear set capacity.

In one-pipe operation, the oil which does not go through the nozzle line is returned directly to the gear inlet and the suction line flow is equal to the nozzle flow. In that case, the by-pass plug must be removed from the return port, and the return port sealed by steel plug and washer.

Bleed

Bleeding in two-pipe operation is automatic : it is assured by a bleed flat on the piston.

In one-pipe operation, the plug of a pressure gauge port must be loosened until the air is evacuated from the system.

Cut-off

The solenoid valve of the AL pump is of the "normally closed" type and is situated in the nozzle line. This design ensures extremely fast response and the switching can be selected according to the burner operating sequence and is independant of motor speed.

When the solenoid is non-activated, the valve is closed and all oil pressurised by the gear set passes through the regulator to the suction or return line, depending upon pipe arrangement.

As soon as the solenoid is activated, oil passes to the nozzle line at the pressure set by the pressure regulating valve.

PUMP IDENTIFICATION

(Not all model combinations are available
Consult your Suntec representative)

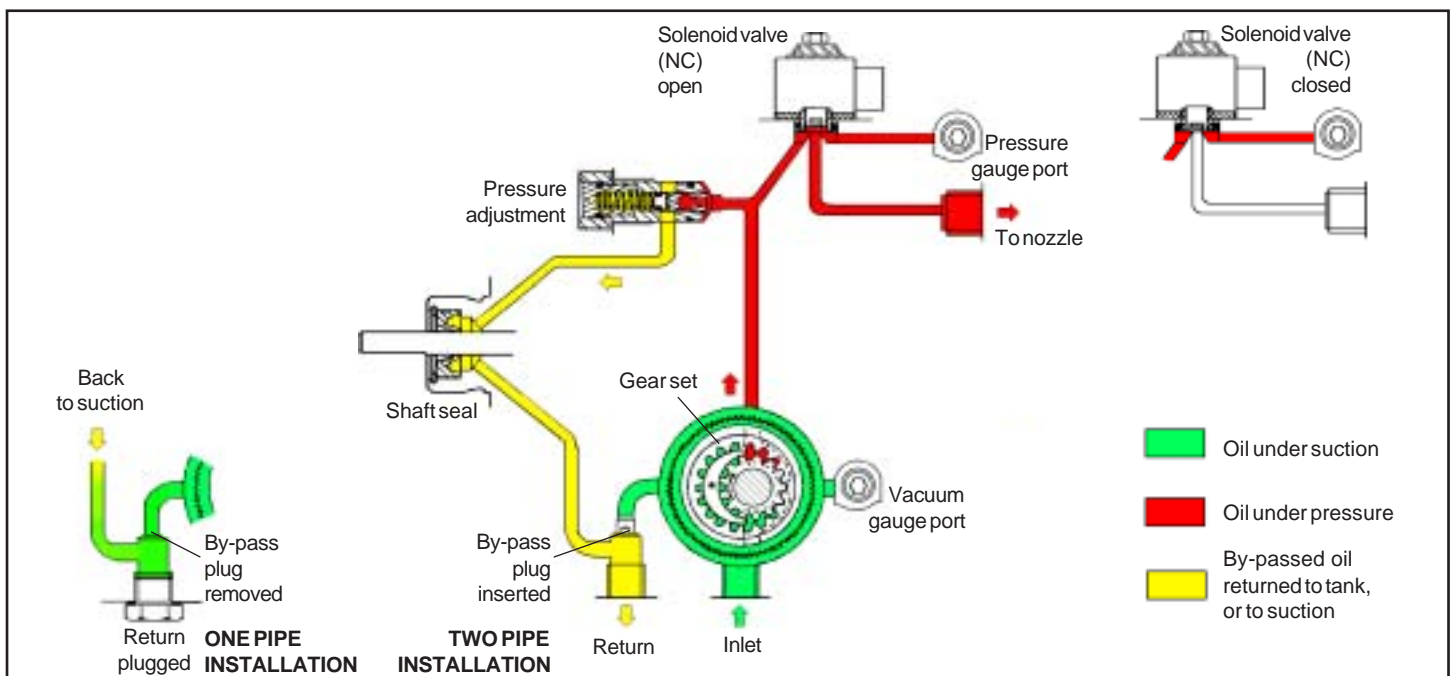
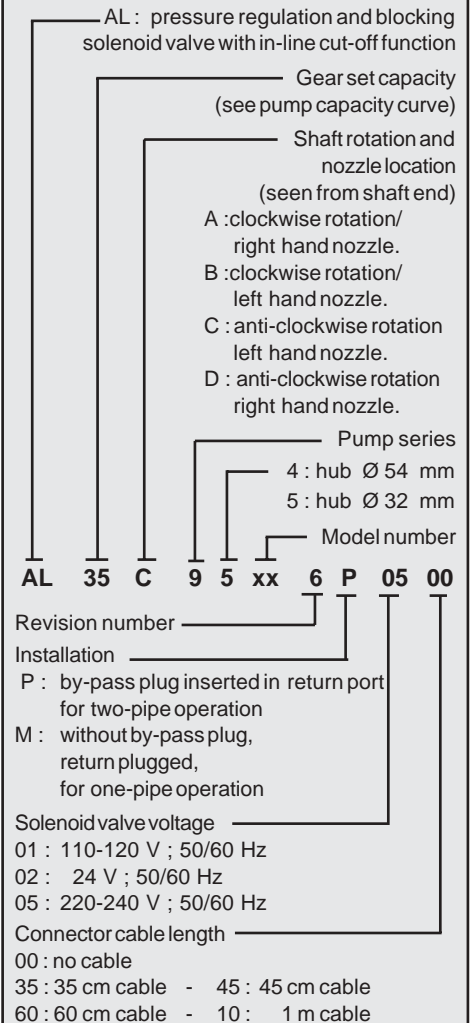

TECHNICAL DATA

General

Mounting	Hub mounting according to EN 225. (Flange mounting available on AL 75/95 models)
Connection threads	cylindrical according to ISO 228/1.
Inlet and return	G 1/4 (with facilities for conical sealing on revision 5 and 6 models)
Nozzle outlet	G 1/8
Pressure gauge port	G 1/8
Vacuum gauge port	G 1/8
Valve function	Pressure regulation.
Strainer	open area : 6 cm ² (AL 35/55/65) - 20 cm ² (AL 75/95). opening size : 150 µm.
Shaft	Ø 8 mm according to EN 225.
By-pass plug	inserted in return port for two-pipe system ; to be removed with a 4 mm Allen key for one pipe system.
Weight	1,1- 1,3 kg (depending on the model).

Hydraulic Data

Nozzle pressure range	8 - 15 bars <i>(other ranges available on request, refer to the specified range of the particular fuel unit)</i>
Delivery pressure setting	9 bars (AL 35/55/65) - 12 bars (AL 75/95)
Viscosity range	2 - 12 mm ² /s (cSt)
Oil temperature	0 - 60°C in the pump.
Inlet pressure	2 bars max.
Return pressure	2 bars max.
Suction height	0,45 bars max. vacuum to prevent air separation from oil
Rated speed	3600 rpm max.
Torque (@ 45 rpm)	0,10 N.m (AL 35/55) - 0,12 N.m (AL 65) 0,14 N.m (AL 75) - 0,20 N.m (AL 95)

Solenoid valve characteristics

Voltage	220-240 or 110-120 or 24 V; 50/60 Hz
Consumption	9 V.A (for voltage = 230 or 110 or 24 V)
Ambient temperature	0 - 60°C
Maximum pressure	15 bars
Certified	TÜV Nr stamped on pump body.
Protection class	IP 41 according to EN 60529, when used with SUNTEC connector cable.

Connector characteristics *(refer to data sheet : "Connectors")*

Pump capacity

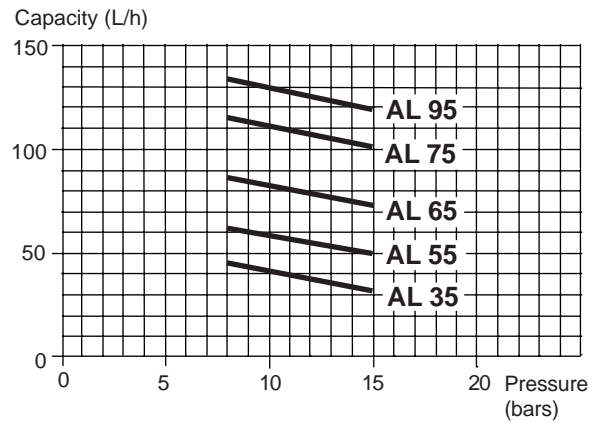

Viscosity = 5 cSt - rated speed = 2850 rpm

Data shown take into account a wear margin.
Do not oversize the pump when selecting the gear capacity.

Power consumption

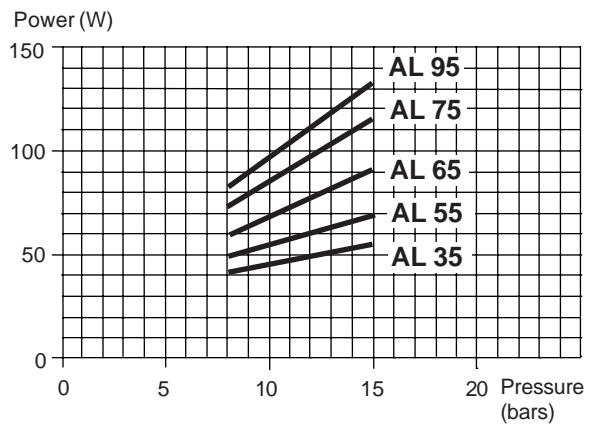

Viscosity = 5 cSt - Rated speed = 2850 rpm

PUMP DIMENSIONS

Examples show "C" rotation and nozzle outlet.

Pumps revision 2, 5

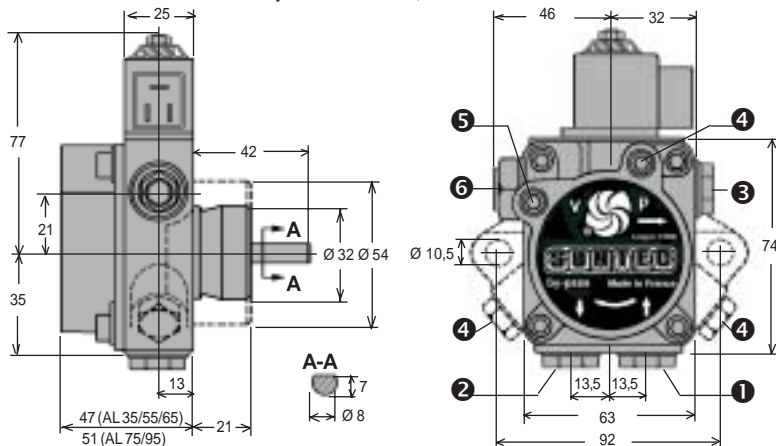

Pumps revision 4, 6

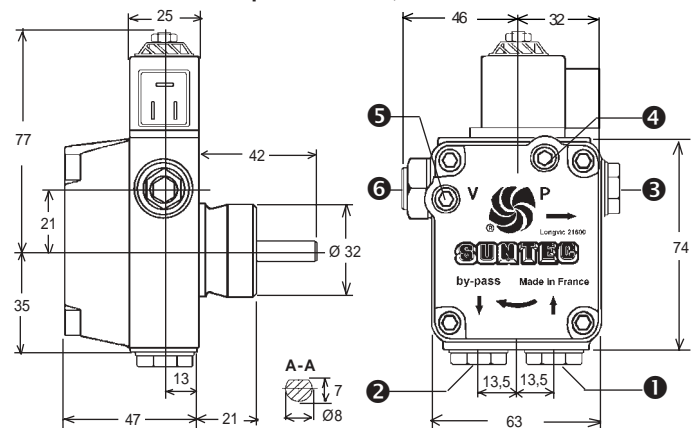

Inlet ① and Return ② with direct sealing for revision 5 and 6 models (sealing with washers can also be used)

- ① Suction
- ② Return and internal by-pass plug
- ③ Nozzle outlet
- ④ Pressure gauge port
- ⑤ Vacuum gauge port
- ⑥ Pressure adjustment